



**Robust valve control device giving a confidence in reliable performance and outstanding durability under harsh working environments**

### Features

- ▶ Easy maintenance
- ▶ Precise calibration with simple SPAN and ZERO adjustments
- ▶ Simple conversion to direct acting or reverse acting
- ▶ 1/2 split range available
- ▶ Rugged aluminum housing with corrosion-resistant coating
- ▶ Vibration resistant design
- ▶ Stainless steel gauges standard
- ▶ Restricted pilot valve orifice kit for small actuators included

### Options

- ▶ High temperature

### Specifications

	PPL	
	Linear Type (Lever Feedback)	
	Single	Double
Input Signal	0.2 - 1.0 bar (3 - 15 psi) (Note.1, 2)	
Supply Air Pressure	Max. 7.0 bar (100 psi)	
Standard Stroke	10 - 80 mm (Note.3)	
Pneumatic Connections	PT(Rc) 1/4 or NPT 1/4	
Ambient Temperature	-20 ~ +70°C (Note. 4)	
Pressure Gauge	Stainless steel	
Output Characteristics	Linear	
Linearity	Within $\pm 1.0$ % F.S	Within $\pm 1.5$ % F.S
Sensitivity	Within $\pm 0.2$ % F.S	Within $\pm 0.5$ % F.S
Hysteresis	Within 1.0 % F.S	
Repeatability	Within $\pm 0.5$ % F.S	
Air Consumption	5 LPM (Sup. 1.4 bar)	
Flow Capacity	80 LPM (Sup. 1.4 bar)	
Body Material	Aluminium die-cast	
Weight	2.1 kg	

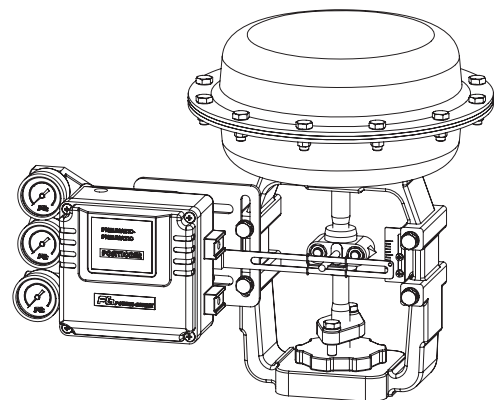

- Note** : 1) 1/2 split range is available for 3~9 psi input signal or 9~15 psi input signal  
 2) Please contact for 6~30 psi input signal  
 3) Feedback lever can be extended to stroke 80 ~ 150mm  
 4) High temperature option : up to +120 °C