



Smartest valve control device meeting a dynamic performance and a precise setting with a piezoelectric technology and an optimized auto-calibration program

Features

- ▶ Auto-Calibration for optimum conditions
- ▶ Precise control performance and high dynamic response
- ▶ Easy operation with four-key pads and full text graphical LCD
- ▶ Single and double acting
- ▶ Low air consumption due to piezo electric microvalve
- ▶ Pressure regulator built-in to eliminate variations in supply air pressure
- ▶ Problem-free characteristics on a small actuator
- ▶ High resistance against shock and vibration
- ▶ Mounting on linear actuators according to IEC 534

Options

- ▶ Position transmitter (4...20mA output signal)
- ▶ 2 x alarm limit (Min., Max.)
- ▶ Explosion proof type (KC Ex d IIB+H₂ T6 IP66)
- ▶ HART communication (FSK)

Specifications

| | |
|---------------------------------------|--|
| Input Signal | 4 - 20 mA @ 24 VDC |
| Voltage Drop | 8.5 VDC @ 20 mA (425 Ω) |
| Min. / Max. Current | 3.6 mA / 50 mA |
| Required Load Voltage (≅ Ω @ 20mA) | Without HART : 8.5V (≅425 Ω) With HART : 9.2V (≅460 Ω) |
| Air Supply Pressure | 1.4 - 7.0 bar (20 - 100 psi) Filtered compressed dry and non-oiled air |
| Output Pressure | 0 - 100% supply air pressure / single or double action |
| Shut-off Value | Range 0 - 5% of position signal |
| Air Capacity | 80 ℓ/min = 4.8 N ^m /h = 2.8 scfm (Sup = 1.4 bar) |
| Air Consumption | 1.3 ℓ/min = 0.08 N ^m /h = 0.05 scfm (Sup = 1.4 ~ 6 bar) |
| Humidity Limits | < 90% RH, non-condensing |
| Stroke / Angle | 5 ~ 80mm (max. up to 150mm) 0 ~ 90° (max. up to 100°) |
| Adjustable Speed | 1 - 1000 (lowest 1, highest 1000) |
| LCD Indication | 4-digit LCD indicator |
| Scan Time | 2 ms |
| Valve Action | Position 0 - 100% / direct action (DA) / reverse action (RA) |
| Characteristic Curve | Linear, E.Q.% (1:25 or 1:50), Quick open Linearity <= 0.3% / sensitivity <= 0.2% / hysteresis <= 0.2% |
| Operating Temperature | - 30 ~ +70 °C |
| Protection Class | IP66, flameproof (KC Ex d IIB+H ₂ T6 IP66) |
| Body Material | Aluminum die-cast |
| Pneumatic Connections | PT(Rc) 1/4 or NPT 1/4 |
| Electrical Connections | 2 x PF(G) 1/2 or NPT 1/2 |
| Weight | 2.5 kg |

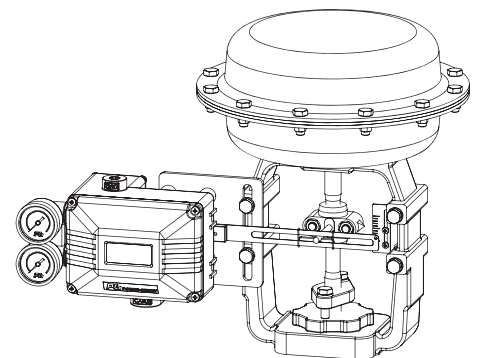

- SSL (Linear Type)

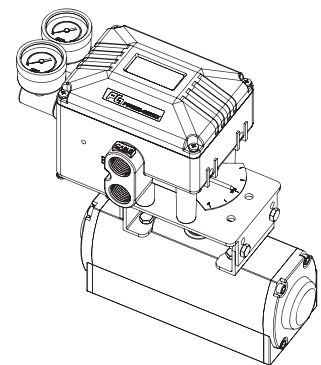

- SSR (Rotary Type)

Note : Equal percentage or Quick-open option is available. Please contact for more details