



TREA 0060 / 0080 ELECTRICAL ACTUATOR USER MANUAL



AUGUST 2022

PLEASE READ THE INSTRUCTIONS BEFORE USE!



www.smstork.com

CONTENT

1. PURPOSE OF DOCUMENT.....	4
2. PRODUCT OVERVIEW.....	4
▶a. Intended Use of the Product.....	4
▶b. Product Coding System.....	5
▶c. Product and Part Pictures.....	6
▶d. Labeling Details.....	7
3. PRODUCT OPERATION.....	8
▶a. Storage Conditions.....	8
▶b. Operation Conditions.....	8
▶c. Protection Measures.....	8
▶d. Options.....	9
4. PRODUCT INSTALLATION.....	9
▶a. Actuator Installation to Valve.....	9
▶b. Manuel Control.....	12
▶c. AdjustingCamsandLimitSwitches.....	12
▶d. Technical Dimensions.....	13
▶e. Atex	13
▶f. Proportional Control Unit.....	14
▶g. PIUPotentiometer Unit.....	15
5. ACTUATOR CONTROL.....	16
▶a. Manual Control with Handwheel.....	16
▶b. Manuel Control on PCB Card.....	16
▶c. Proportional Card Adjustment.....	17
Control Signal Selection.....	17
OutputSignal(Feedback)Selection.....	17
Error Positions.....	17

Reversible Control Signal.....	18
Reversible Output Signal.....	18
Automatic Calibration.....	18
Restart in Protection Mode.....	19
►d. The meaning of LED lights.....	19
6. CONNECTION DIAGRAMS.....	21
7. WARNINGS.....	26
8. PRODUCT LIFE.....	26
9. PRODUCT MAINTENANCE.....	27
10. PRODUCT SPARE PARTS.....	29
11. PRODUCT SHIPMENT.....	29
12. WARRANTY CONDITIONS.....	29

1. PURPOSE OF DOCUMENT

This document is prepared for showing TORK brand named electrical actuators' installation, operation and maintenance information.

Security Notifications:



Warning: This sign Show personal and product's security notifications. It warns user about probably dangers. If cautions are not regarded personal injuring or product damaged is become unavoidable.

2. PRODUCT OVERVIEW

Electrical actuators are equipment converting electrical power to mechanical power used for valve control. Electric motor's torque is transmitted to valve shaft through the electrical actuator gearbox. This torque makes the valve open or close. Gearbox provides a steady torque while turning.

The resulting motion performs the on - off function of the valve coupled to the actuator. Depending on the feature of the coupled valve and customer request related to flow control, it is produced as Open-Close Control Electric Actuator, Proportional Control Electric Actuator, Battery Electric Actuator and Onsite Controlled Electric Actuator.

a. Intended Use of the Product

Electric actuators are among the most used control elements in valve control. The duties of electric actuators can be summarized as providing the valve to open, closing the valve, or keeping the valve in the desired opening. Electric actuators can be used in different applications, either ON / OFF or PROPORTIONAL. Electric actuators are used to control many valves such as ball valves, butterfly valves and plug valves.

Reasons of using electric actuators,

- Electric power is accessible.
- High output torque can be produced with low energy.
- Products have longer life.
- Products are compact and have light weight.
- Sensitive proportional control.
- High protection class.
- Wide power supply range.
- Wide turn angle range.

b. Product Coding System

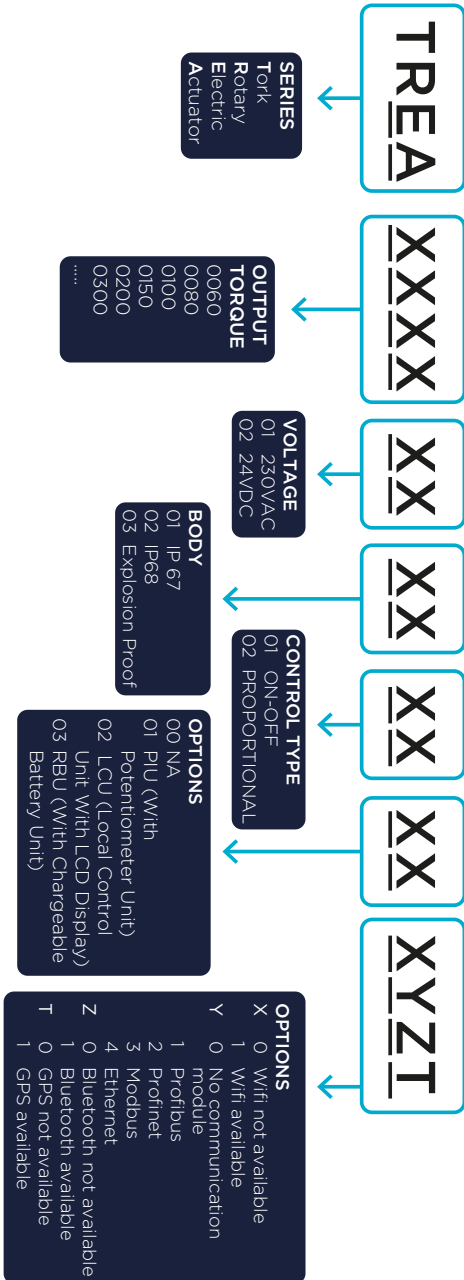

Table 1. Product Coding System

c. Product and Part Pictures

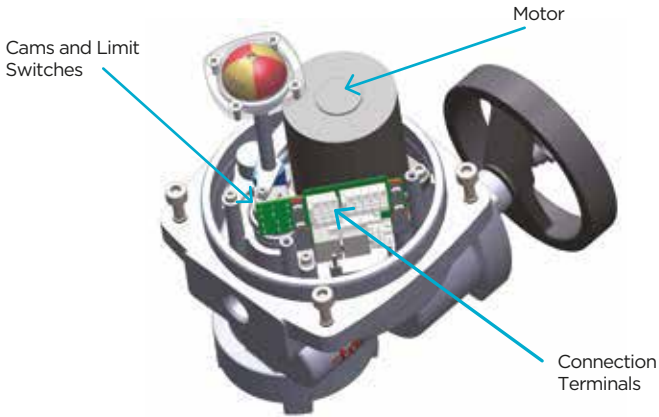

Fig 1. Electrical actuator inner parts

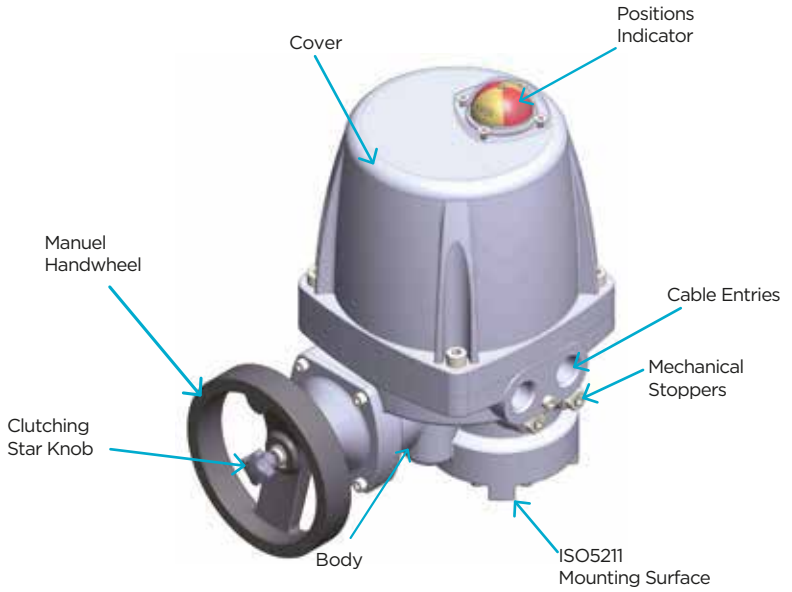

Fig 2. Electrical actuator outer parts

* TORK electrical actuators don't contain no asbestos, quicksilver, PCB and other prohibited chemicals.

d. Labeling Details

Electrical actuators' general information must be written on their labels. Fig 3 shows a sample label and the information it contains. For more detailed information, the user manual, technical support department or sales department can be helpful.

Electrical actuator label contains these informations:

- Model
- Type
- Serial No
- Protection Class
- Ambient Temperature
- Output Torque
- Operation Voltage
- Power
- Operation Time
- Optional Units

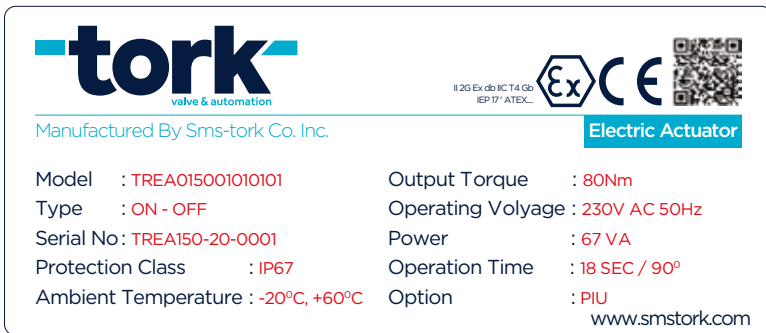

Fig 3. Label

Product Code	Maximum Output Torque	Working Current	Mechanical Power	Electrical Power	Opening Closing Time	Protection Class	Working Temperature	Kg
TREA006002010100	Aç / Kapat	24 VDC	60 Nm	84 W	14 sn	IP67	-20 °C~+60 °C	7.2
TREA006001010100	Aç / Kapat	230 VAC 50/60Hz	60 Nm	69 W	14 sn	IP67	-20 °C~+60 °C	7.2
TREA008002010100	Aç / Kapat	24 VDC	80 Nm	89 W	14 sn	IP67	-20 °C~+60 °C	7.2
TREA008001010100	Aç / Kapat	230 VAC 50/60Hz	80 Nm	108 W	14 sn	IP67	-20 °C~+60 °C	7.2
TREA006002010200	Oransal	24 VDC	60 Nm	84 W	14 sn	IP67	-20 °C~+60 °C	7.2
TREA006001010200	Oransal	230 VAC 50/60Hz	60 Nm	69 W	14 sn	IP67	-20 °C~+60 °C	7.2
TREA008002010200	Oransal	24 VDC	80 Nm	89 W	14 sn	IP67	-20 °C~+60 °C	7.2
TREA008001010200	Oransal	230 VAC 50/60Hz	80 Nm	108 W	14 sn	IP67	-20 °C~+60 °C	7.2

Table 2. Label values according to product codes

3. PRODUCT OPERATION

When supply voltage (230VAC or 24VDC) applied to the electrical actuator, motor and gearbox produce a rotary force. This force makes the valve acting. According to this act valve is opened or closed.

a. Storage Conditions

Electrical actuators must be stored in clean, dry and cool ambient. Electrical actuators' cover screws must be tightened up and cable entries must be closed. When electrical actuators are stored in an open ambient, they must be protected from weather conditions.

b. Operation Conditions

Actuator Weight	: 7.2 kg
Operation time	: 18sn/ 90°
Body Ingress Protection	: IP67 on request IP68
Body Material	: Aluminum Die Cast
Body Coating	: Electrostatic Powder Coat
Power Source	: 230 VAC, 24VDC
Motor	: AC Reversible Motor, DC Brushed
Limit Switches	Motor : 2x On / Off SPDT, Max 250VAC
Aux. Limit Switches	3A
Position Indicator	: 2x On / Off SPDT, Max 250VAC 3A
Manuel Control	: Continuous, as OPEN/CLOSE
Inner Heater	: Hand wheel
Cable Entrances	: 2W
Greasing	: M20x1,5
Ambient Temperature	: Gear Oil : From -20°C to + 60°C
Recommended Protection Fuse	: 4A Type B Automat Fuse
Clutch System	: with handwheel for using manual control, automatically exit from manual control
Supply Cable Specifications	: Tinned copper braided, stranded, shielded, 1 mm ² cable

c. Protection Measures

Our proportional electrical actuators have high current protection, high voltage protection, power card protection, overtemperature protection and delay time protection against sudden reverse operation. If the product enters any of these protections, determine the reasons for the protection before restarting, and perform work that will prevent it from reoccurring.

d. Options

- Position indicator LEDs
- Proportional Control Unit
- RBA – Rechargeable Battery Unit
- IP68 Working Underwater Conditions (Up to 96 hours at a depth of 10 meters)
- ATEX Certificated Body(Ex II 2G Ex IIC T4 Gb)
- LCA Local Control Unit with LCD Screen
- Profibus, profinet, ethernet
- Bluetooth
- Wifi
- GPS

4. PRODUCT INSTALLATION

Before installation, it must be checked if there is any damage on the product and there is any missing part. If there is any damage or missing part, product must not be accepted. Before the installation information on the labels and the boxes must be checked. Before the installation, line voltage and voltage written on the label must be checked if they are in the same range. Before the installation product's suitability to the system must be checked. The working limits stated in the technical specifications should not be exceeded. Before the installation, the line voltage must be switched OFF. Be careful about during the installation if anybody can switch it ON. This probability must be prevented and must be sure about it.

a. Actuator Installation to Valve

Electric actuators are manufactured to be mounted on valves according to ISO5211 standard.

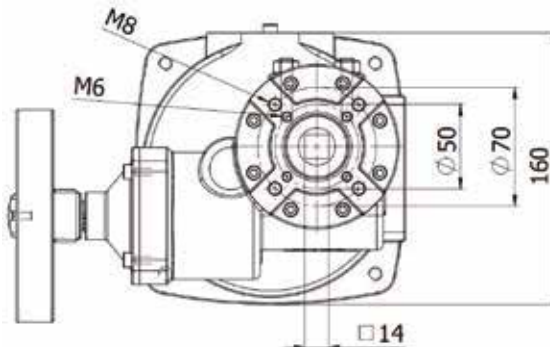

Figure 4. ISO 5211 Sizes

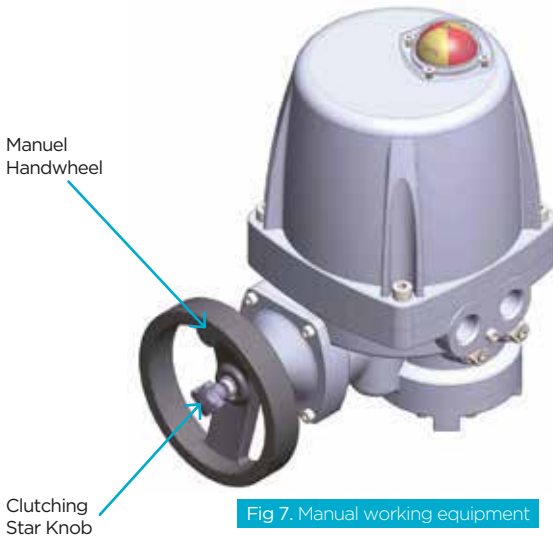

Fig 5. Electric Actuator Installation to Valve



Figure 6. Mounting the Electric Actuator to the Valve with Bracket

b. Manuel Control



The handle in the center of the manual handwheel is pulled back so that the actuator is in manual control. Manual handwheel is turned according to the opening or closing direction. To switch from manual control to electrical control, the actuator is powered and the automatic actuator switches itself when the motor rotates.

c. Adjusting Cams and Limit Switches

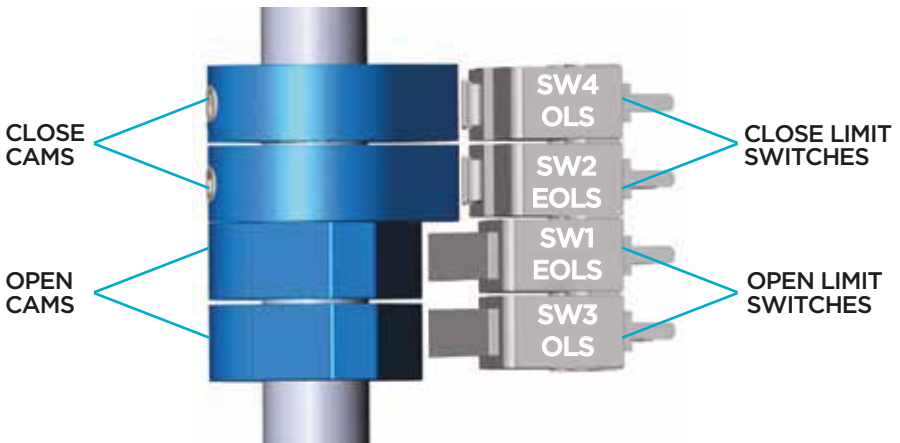

Fig 8. Cams and limit switches

Firstly, loosen the setscrew on cams. Cams should be able to move freely independent of the shaft.

The actuator is manually moved to the OFF position. When in the CLOSED position, the cam is rotated to suppress the CLOSE limit switch cam.

After pressing the CLOSE limit switch, the CLOSE cam is fixed.

The same operations are made for the OPEN position with the OPEN cam.

d. Technical Dimensions

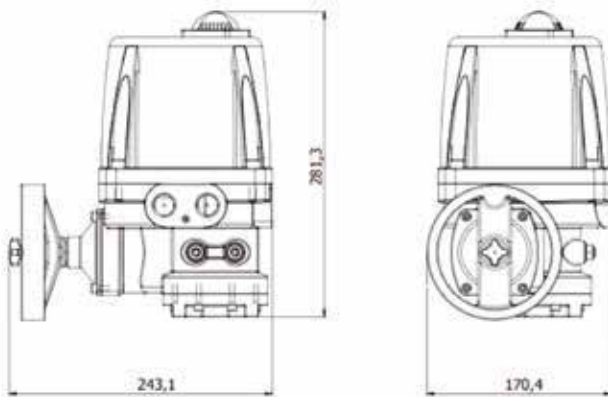

Fig 9. TREA Electric Actuators ABC Measures

e. Atex (2014 / 34 / EU)

Atex electrical actuators are the products that are used in potentially explosive or hazardous environments. There are important requirements to be aware of when using these products. In the event that one or more of these conditions are not met, the user is liable. Atex products;

- Must be used with Atex certified appropriate coupling,
- Must be used with Atex certified appropriate cable.
- The product cover should never be opened when actuator is in energy.
- Grounding must be done.
- Use for grounding min 4 mm² cable produced in HD21 or HD22 standards .
- It is suitable for use in ZONE 1 and ZONE 2 environments (Ex II 2G Ex IIC T4 Gb).
- Our actuators are manufactured according to LVD and EMC directives.

f. Proportional Control Unit

Proportional control unit is a control unit on electric actuator to provide turning the valve on/off in desired angle between 0 - 90° degree.

The sent analog signal, proportionally provides motor to turn on/off the valve in a certain rate. Detects the information of current position of the valve and gives a proportional analog signal output.

TECHNICAL FEATURES	
Body Ingress Protection	IP67
Body Material	Aluminum Die Cast
Body Coating	Electrostatic Powder Coat
Power Source	230 VAC, 24VDC
Control Signal	0/4 - 20 mA, 0/2 - 10 mA, 0/2 - 10V DC, 0/1 - 5V DC
Output Signal	0/4 - 20 mA, 0/2 - 10 mA, 0/2 - 10V DC, 0/1 - 5V DC
Reversible Control Signal	It can be adjusted via switches on the control card.
Reversible Output Signal	It can be adjusted via switches on the control card.
Automatic Calibration	It can be adjusted via buttons on the control card.
Fail Positions	Stay still, Turns the valve on, Turns the valve off
Adjustable Max. Valve Degree	Between 0° - X° adjustable special valve degree
Self Protection	PST (Partial Stroke Test) Voltage protection, Valve jam detection, Over and under temperature protection, Moisture protection, Delay time protection against sudden reverse operation
Motor	24V DC Motor / 230V AC motor
Limit Switches	2x Open/Close SPDT, Max 250VAC 3A
Aux. Limit Switches	2x Open/Close SPDT, Max 250VAC 3A
Position Indicator	All locations
Manuel Control	With handwheel & Via buttons on control card
Inner Heater	2W
Cable Entrances	M20x1.5
Ambient Temperature	-20°C to +60°C

OPTIONAL FEATURES	
LED Indicator	
RBA - Rechargeable Battery	
IP68 Protection Class (Up to 96 hours at a depth of 10 meters)	
ATEX Certificated Electric Actuator (230 VAC, 24VDC)	
LCA: Local Control Unit with LCD	

Table 2. Technical Features

g. PIU Potentiometer Unit

Adding PIU (potentiometer unit) to the TREA series on-off electric actuator enables to reach the instant position information of the valve and to keep the valve in the desired position. By managing the relay with PLC, the actuator can be operated at the desired angle (0° - X°).

An exemplary connection diagram is shown in Figure 10, and the location of the PIU on the product is shown in Figure 11.

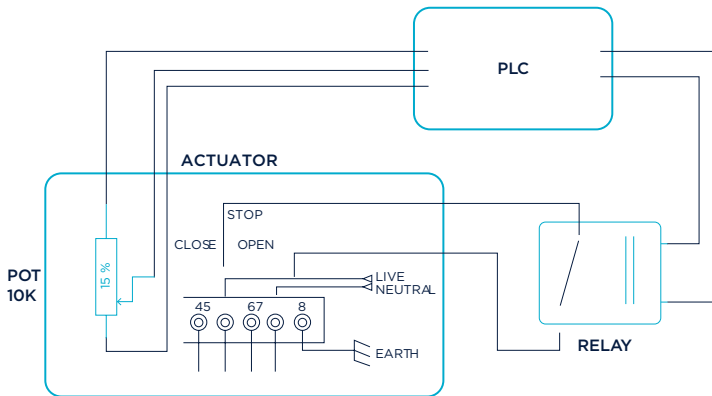

Figure 10. Connecting PIU to the On-Off electric actuator

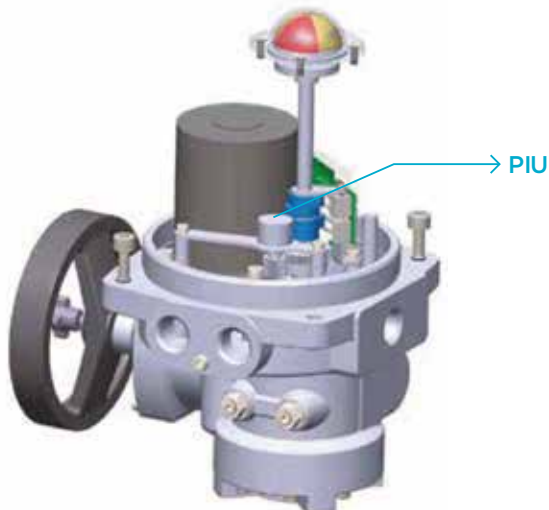

Figure 11. Electric actuator with PIU added

5. ACTUATOR CONTROL

There are two ways to manually control the TREA Proportional Electric Actuator:

a. Manual Control with Handwheel

The handwheel control method is used in both on-off and proportional electric actuators. This method is recommended when there is no electricity in the system or for emergencies such as power failure and loss of control signal. The reason why the proportional electric actuator is recommended in this way is that while the control signal is still applied to the actuator, when the valve is turned by hand, the actuator will try to correct its position again according to the control signal applied. Before this control is achieved, it is recommended to bring the proportional electric actuator into manual mode with the help of switches on the PCB board.

The handle in the center of the manual handwheel is pulled back so that the actuator is in manual control. Manual handwheel is turned according to the opening or closing direction. To switch from manual control to electrical control, the actuator is powered and the automatic actuator switches itself when the motor rotates.

b. Manuel Control on PCB Card

If pin 1 of the 5 pin SETTINGS switch shown in Figure 12 is in the closed position (below), the electric actuator is disconnected from the control signal and the electric actuator can be controlled by pressing the OPEN and CLOSE buttons on the PCB.

Caution: To be able to automatically control the electric actuator with the control signal, pin 1 of the SETTINGS switch must be in the ON position (above).



Figure 12. Control buttons and SETTINGS Switch

c. Proportional Card Settings

- Control Signal Selection

Control signals are selected with the INPUT switch shown in Figure 13. Proportional electric actuators are factory adjusted according to the 4-20mA control signal. The control signal selection can be made according to Table 4 by changing the pins of the INPUT switch.

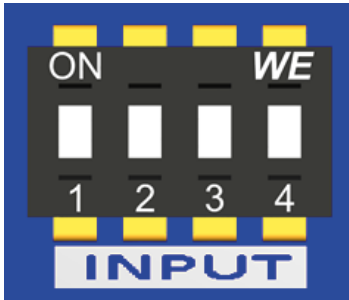

Figure 13. Input control signal selection switch

INPUT CONTROL SIGNAL ADJUSTMENT SWITCH				
Control Signals	Pin Positions			
	1	2	3	4
0 - 10 mA	OPEN	CLOSE	CLOSE	CLOSE
0 - 20 mA	OPEN	CLOSE	CLOSE	OPEN
2 - 10 mA	OPEN	CLOSE	OPEN	CLOSE
4 - 20 mA	OPEN	CLOSE	OPEN	OPEN
0 - 5 V DC	CLOSE	OPEN	CLOSE	CLOSE
0 - 10 V DC	CLOSE	OPEN	CLOSE	OPEN
1 - 5 V DC	CLOSE	OPEN	OPEN	CLOSE
2 - 10 V DC	CLOSE	OPEN	OPEN	OPEN

Table 4. Control Signal of Proportional Electric Actuator

- Output Signal (Feedback) Selection

Output signal selection is made with the OUTPUT switch shown in Figure 14.

Proportional electric actuator is set to 4 - 20 mA output signal as factory setting. Output signal selection with OUTPUT switch is shown in Table 5.



Figure 14. Output Signal (Feedback) Selection Switch

OUTPUT CONTROL SIGNAL SELECTION SWITCHER			
Control Signals	Pin Positions		
	1	2	3
0 - 10 mA	CLOSE	CLOSE	CLOSE
0 - 20 mA	CLOSE	CLOSE	OPEN
2 - 10 mA	CLOSE	OPEN	CLOSE
4 - 20 mA	CLOSE	OPEN	OPEN
0 - 5 V DC	OPEN	CLOSE	CLOSE
0 - 10 V DC	OPEN	CLOSE	OPEN
1 - 5 V DC	OPEN	OPEN	CLOSE
2 - 10 V DC	OPEN	OPEN	OPEN

Table 5. Output Signal Selection Table

- Error Positions

When the input control signal connected to the proportional electric actuator is interrupted for any reason, the actuator behaves according to the pre-set action with the SETTINGS switch. In the loss of signal, there are 3 different settings: keep the valve in its position, open the valve and close the valve. As the factory setting, the valve is set to remain in its

position. The setting positions made with pins 4 and 5 of the SETTINGS switch shown in Figure 12 are shown in Table 6.

SETTINGS HATA POZİSYONLARI SEÇİMİ		
Error Position	Pin 4	Pin 5
Stay in Current Position	CLOSE	CLOSEI
Open Valve	OPEN	CLOSE
Close Valve	CLOSE	OPEN

Table 6. Selection Table of Proportional Electric Actuator's Error Positions

• Reversible Control Signal

The proportional electric actuator is set at the factory to close at a low signal level and to open at a high signal level. If it is desired to be controlled by applying the reverse control signal, pin 3 of the SETTINGS switch should be turned ON (Up).

For example;

If the control signal is set to the 4 - 20 mA control signal, the actuator acts as follows when the 4 - 20 mA control signal is applied:

If switch 3 is in the 'ON' position

4mA : Fully opened

20 mA : Fully closed

If switch 3 is in the 'CLOSE' position

4 mA : Fully opened

20 mA : Fully closed

• Reversible Output Signal

The user can reverse the input signal as well as the feedback signal. This setting can be made by setting the pin 2 of the SETTINGS switch to the ON (Up) position. Based on the example given in the input signal, normally the electric actuator will output 4mA when the valve is in full closed position, and will output 20mA when the output reverse setting is made. This setting is valid for all output signal types.

• Automatic Calibration

Electrical connections and cam settings are made. The pin (1) of the SETTINGS switch is set to the OFF (Down) position. The SET and OPEN keys shown in Figure 15 are pressed at the same time. While the power led is constantly lit, the green, yellow, blue and red leds will light together, and then the electric actuator will begin automatic calibration. In this case, the keys are released. When automatic calibration starts, the electric actuator will primarily close the valve completely. During the closing process, the RGB1 led will flash

blue and green, and will light green in the fully closed position.

Then it will open. The RGB1 led will flash red and blue during the opening process, and the RGB1 led will light red in fully open position. When the calibration process is completed successfully, the leds will turn off one by one and the calibration will be completed. Thus, the proportional electric actuator will detect in which angle range it operates and will provide a smooth control. If the automatic calibration process is interrupted for any reason, please calibrate it from the beginning.



Figure 15. Buttons used for automatic calibration

! In order to perform automatic calibration, the cams should be adjusted to contact the switches in positions where the valve is fully open and fully closed.

• Restart in Protection Mode

Proportional electric actuators automatically protect themselves when exposed to excessive torque or high temperature. When the actuator protects itself, it activates the fault relay and illuminates the leds on the control card according to the fault mode to indicate which of the over torque or high temperature protections. The actuator can be restarted by following the steps below after the failures related to over torque protection or high temperature are eliminated.

- 1) It is taken into manual control over PCB board,
- 2) Valve clamping is eliminated, if any, by manual control with OPEN CLOSE keys or hand wheel.
- 3) Protection is exited by holding down the SET and CLOSE keys simultaneously for 5 seconds,
- 4) By holding down the SET, OPEN keys simultaneously, the leds are expected to light up (green - yellow - blue - red) respectively. When the leds are lit, automatic calibration is started and automatic calibration is performed.

d. Meaning of LED Lights

There are two different led groups on the actuator control board, RGB1 and sequential. These LEDs light up in different patterns for operation, orientation and information. The table below contains the meanings of the leds. S in the table refers to sequential combustion and F flashing.

Working mode	Red Led	Blue Led	Yellow Led	Green Led	RGB Led	Description	
Automatic Mod				Green		Working in automatic mode	
Manual Mod		Blue				Working in manual mode	
Automatic Mod				Green	F	F	Opening
				Green		F F	Closing
				Green	Red		Fully open
				Green		Green	Fully close
				Green		Blue	Middle
Manual Mod		Blue			F	F	Opening
		Blue				F F	Closing
		Blue			Red		Fully open
		Blue				Green	Fully close
		Blue				Blue	Middle
Malfunction Mode	F		Yellow				Not Opened/ closed warning
	F						High temperature/ high moisture
	F	Blue	Yellow				Low temperature
	F		F				No input signal
	F	F					No position information
PST Mode	Red	Blue	Yellow				PST test cannot be done
		Blue	Yellow				PST test in progress
		Blue			F	F	Opening valve
		Blue				F F	Closing valve
		Blue			Red		Fully open
					Blue	Middle	
Calibration Mode	S	S	S	S			SET and OPEN buttons pressed for 3 seconds
		Blue				F F	Calibration started, valve is closing
		Blue				Green	closing calibration completed
		Blue			F	F	Opening valve
	F	F	F	F	Red		Opening calibration completed
						Calibration finished	

Table 7. Meanings of Led lights

6. WIRING DIAGRAMS

The meanings of the signs on the connection cards used in electric actuators are given in the table below;

Symbols	Explanations
L	Live connection point on AC supply,
N	Neutral connection point on AC supply
24V	+24 V connection point on DC supply,
GND	-24 V connection point on DC supply,
+ IN	Positive (+) voltage or current pin connection point to be controlled in proportional controls
- IN	Negative (-) voltage or current pin connection point to be checked in proportional controls
+ OUT	Positive (+) voltage or current pin connection point where position information is to be taken in proportional controls
- OUT	Negative (-) voltage or current pin connection point where ground information is to be taken in proportional controls
COM	The connection point of the desired voltage to be taken from the contacts of the micro switches,
NO	Normally open connection point for micro switches,
NC	Normally closed connection point for micro switches,
Ground Symbol	The connection point of the device ground connection,

Table 8. Symbols and explanations on connection cards

230VAC On-Off Wiring Scheme

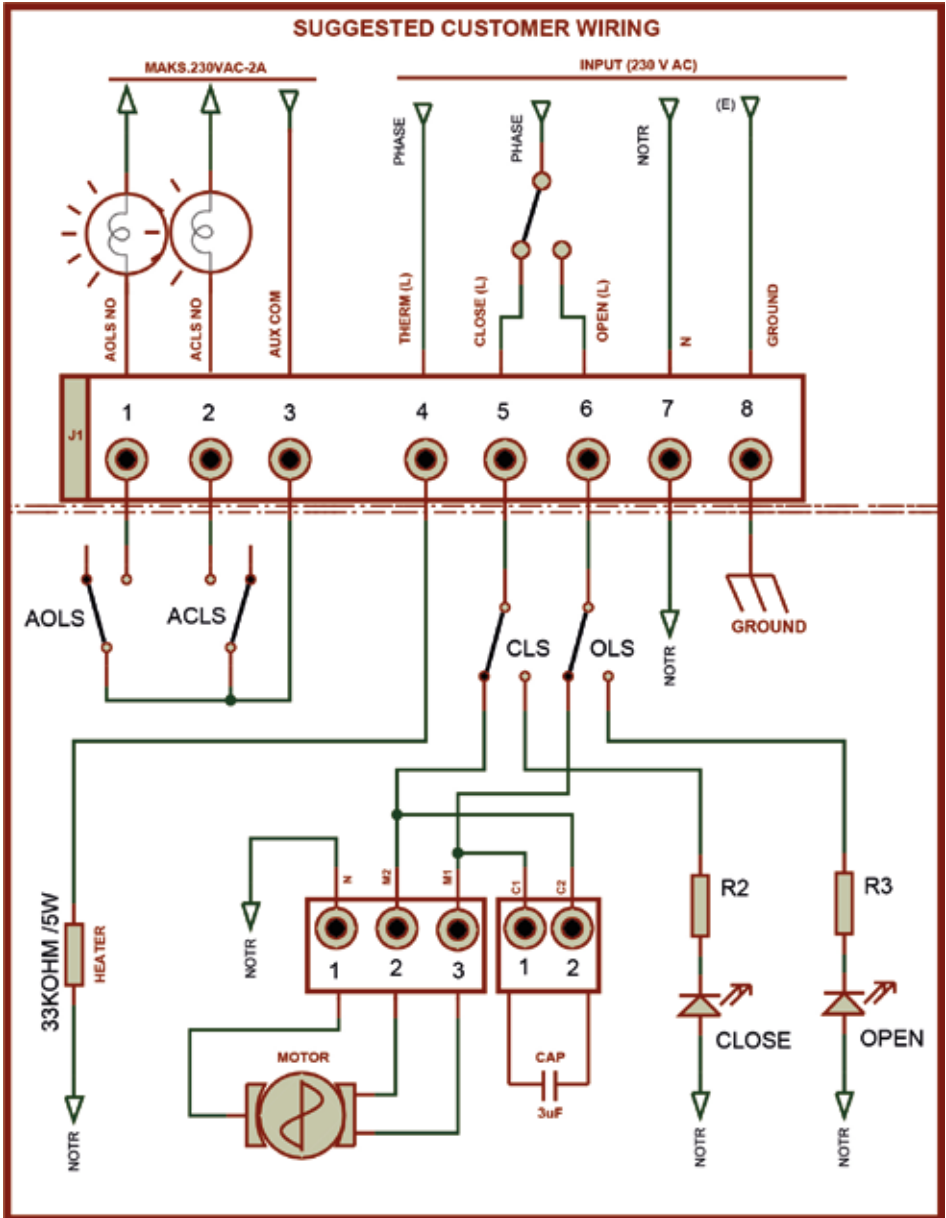

24VDC On-Off Wiring Scheme

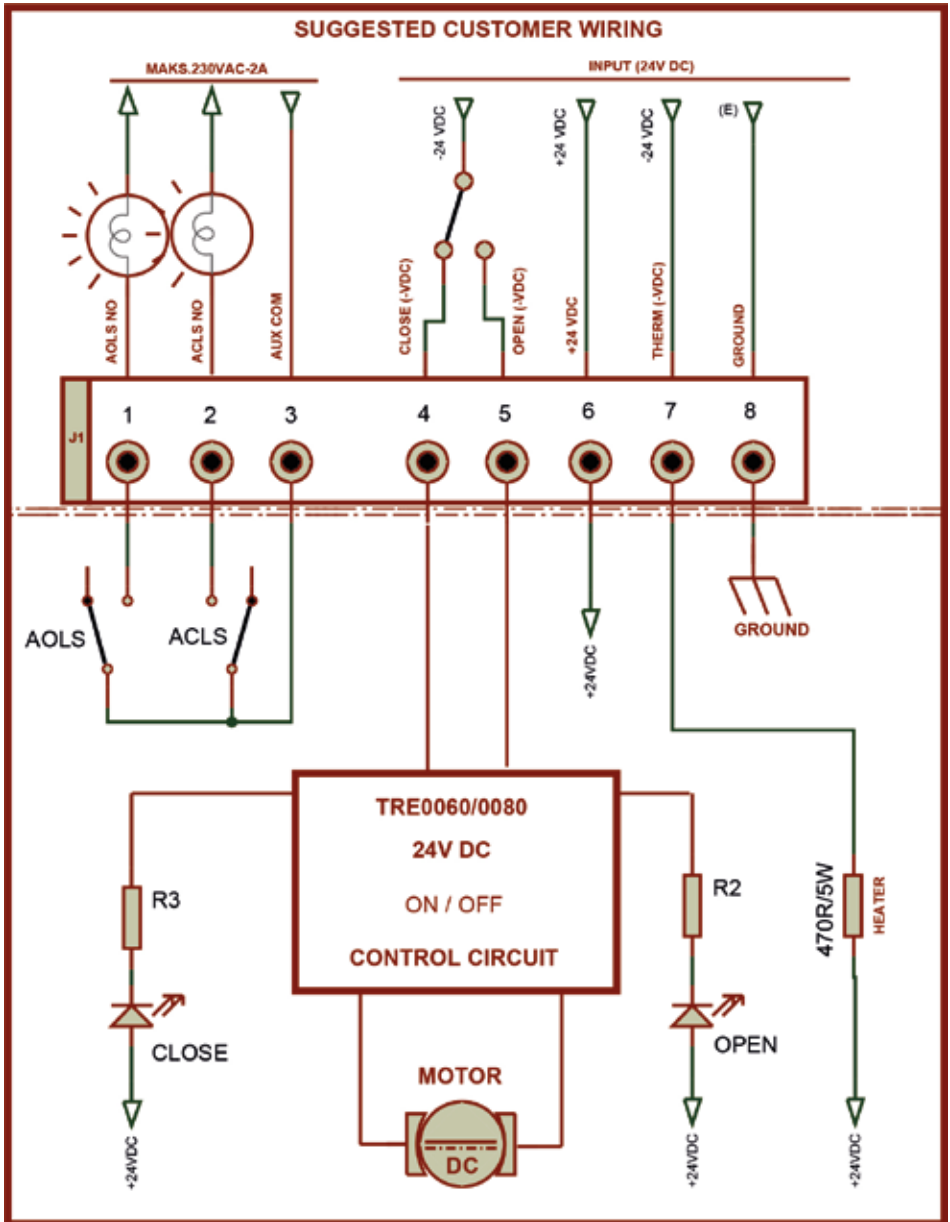

230 VAC Proportional Electric Actuator Wiring Scheme

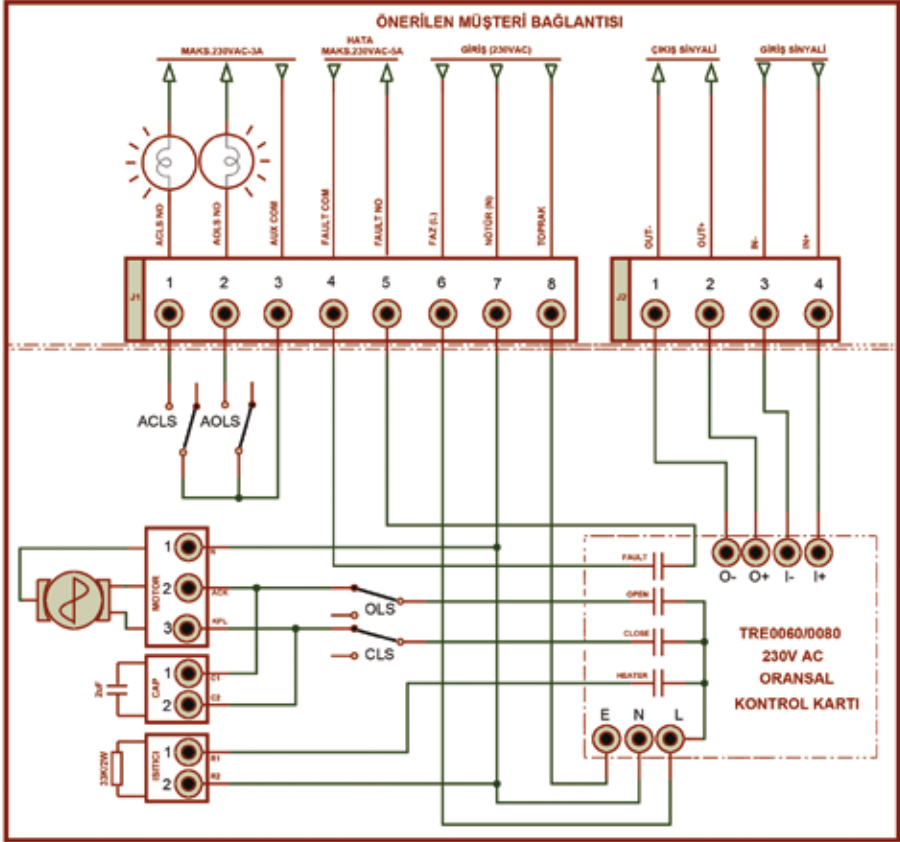

24 VDC OProportional Electric Actuator Wiring Scheme

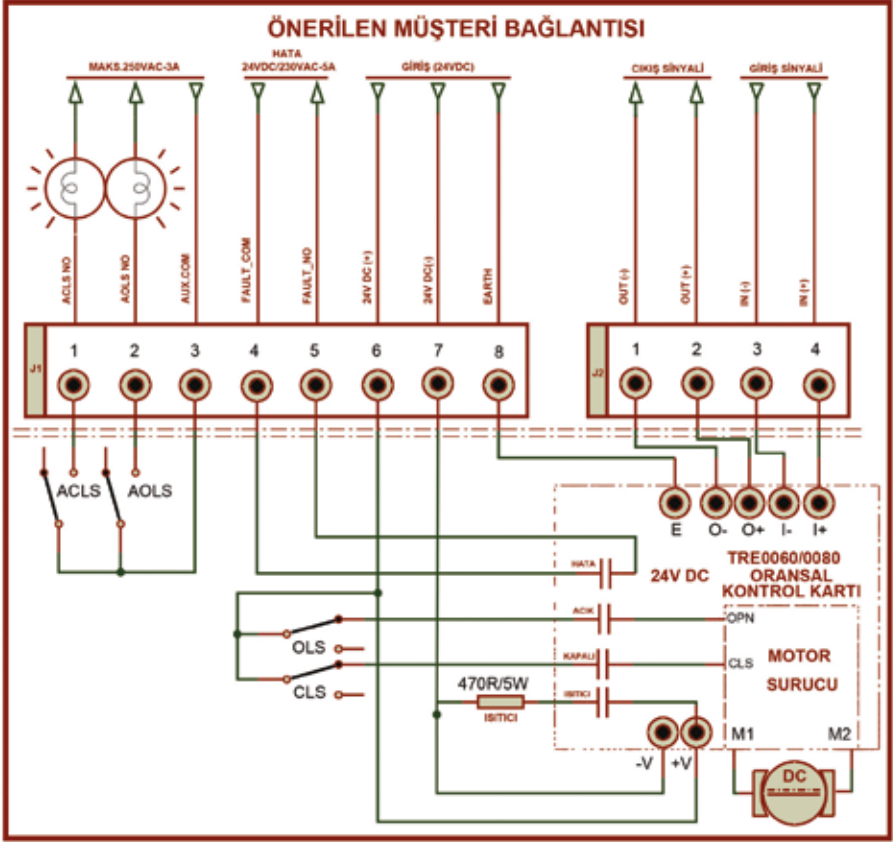

7. WARNINGS

! If electrical actuator's wiring is damaged, it must be changed by producer company, certificated service or someone having technical qualification, for preventing any dangerous conditions. If the product is to be used in outdoor, explosive or in environments where harmful animals such as mice live, It is necessary that the supply cables and the connection materials have the appropriate specifications (armor-plated, atex, etc.).

! A 4 Amp B type vending machine fuse should be added to the line where the electric actuator is connected against any short circuit failure.

! Every electrical actuator must be supplied with voltage written on it.

! Every electrical actuator must be mounted the proper valve according the output torque written on it.

! When it is necessary in some fluid applications, a filter must be used. Because, some sediments gathered in the valve cause corrosion and forcing the electrical actuator. This forcing makes difficult to open or close the valve and can damage the electrical actuator.

! Before removing the electric actuator from the system, the voltage on it must be cut off.

! In case of hand lever reach to the end please do not force it to more turn.

! Preventing from any short circuit or open circuit fault, the electrical actuator cables must not have any damage(twisting, smashing) on them. Moreover, the cable twisting on the cable entries can cause to moisture or water entrance to the body. To prevent from this, proper cable diameter must be selected according to the cable entries.

! Used cable must have minimum 1 mm² section.

8. PRODUCT LIFE

Operation times vary depending on the model of electric actuators. Product life is variable according to the operating conditions of the product such as daily working time, ambient temperature, humidity, whether the applied voltage is variable or not. The duty class level of the motors used in our electric actuators is S2. Therefore, if the motors are to be operated without interruption in AC ON-OFF electric actuators, they should be operated for a maximum of 30 minutes, then the motor temperature should not be operated until it reaches the ambient temperature. Periodic maintenance extends product life.

9. PRODUCT CARE AND MAINTENANCE

Under normal conditions, the electrical actuator must be checked in every 6 months. For more hazardous conditions, it must be checked more frequently.

Before electrical actuator displaced from the system, the power on the electrical actuator must be switched OFF and pressure in the pipe must be zero.

- Be sure about valve and actuator mounting is right.
- Be sure about all electrical wiring is isolated and wired regularly.
- Be sure about all screws are mounted and tightened up.
- Be sure about the parts in the electrical actuator is clean.
- Be sure about cable glands and blind plugs are mounted and dry.
- Be sure about if there is no humidity in actuator.
- Be sure about inner heater is working. The internal heater prevents the formation of moisture inside the actuator and prevents the electronic parts from breaking down.
- Be sure about is manual hand wheel is operating.
- Be sure about actuator's position indicator and valve position are correlate.
- Be sure about label is readable. If it is necessary request to change the label with more readable one.

 During both installation and maintenance be careful about sensitive inner parts. They must not be damaged. Before and after any maintenance electrical wirings must be controlled, electrical precautions must be taken; valve must be tested if it is working proper with actuator.

Problem	Probably Case	Corrective/Preventive Action
The motor is not spinning.	There is an open in control circuit.	Wiring scheme must be checked.
	Motor isolation is damaged.	Motor windings must be checked with Megger Test.
	There is no supply voltage	Supply voltage must be greased.
There is no energy on the product.	Valve shaft is not greased enough.	Valve shaft must be greased.
Valve only opens or closes.	Gearbox has a grease problem.	Gearbox and gears must be greased.
	Valve has jammed.	Valve maintenance must be repeated.
	Limit switch adjusting has gone off.	Limit switches must be checked and must be adjusted again if it necessary.
Manual on / off handle does not control the valve.	Gears turn useless.	Stripped gears must be changed with proper one.
	Manual handwheel's shaft has broken down.	Broken shaft must be changed with proper one.
	Valve shaft has broken down.	Valve shaft must be changed.
The motor is turning but the valve is not opening / closing.	Gears turn useless.	Stripped gears must be changed with proper ones.
The proportional actuator does not give position information.	Potentiometer gears turn useless.	Gear must be tighten up with setscrew.
	Proper signal is not selected with DIP switches.	Signal adjusting must be done with DIP switches according to wanted signal type.
	Electronic cards has damaged.	Electronic card must be changed.
The proportional actuator could not turn on / off the valve at the desired value.	There is no input signal.	Warning LEDs and input/output signal wirings must be checked.
		Input signal type and signal choosing DIP switches must be checked collaterally.
	Potentiometer gears turn useless.	Gear must be tighten up with setscrew.
	Electronic card has damaged.	Electronic card must be change.

Table 9. Malfunctions and possible causes

10. PRODUCT SPARE PARTS

Electrical actuators' spare parts are;

- Gears
- Motor
- Electronic Control Cards
 - On-Off Control Cards
 - Proportional Control Cards
- Position Indicator
- Potentiometer Unit

You must choose spare parts according to your actuator model. For supplying spare parts and detailed information please contact to SMS TORK.

11. PRODUCT SHIPMENT

During transportation be careful about electrical actuator's not falling down and not being subjected hard knocks. Don't put any weight damaging the product on electrical actuator boxes. Electrical actuators must be carried on their carton boxes.

12. WARRANTY CONDITIONS

- 1) The period of warranty shall start from the date of delivery of the product to the customer and shall cover a period of 2 years.
- 2) Every and all parts of the product are under SMS Sanayi Malzemeleri Üretim ve Satışı A.Ş. warranty coverage. (against any defect that may occur during production, assembly and/or defective parts)
- 3) In the case that the product fails within warranty period, the time spent on the repair work is added to the warranty period. Repair time of the product is maximum 20 (twenty) working days. This time starts from the date on which the failure concerning the product is notified to the service station and to seller of the product, dealer, agency, representative, importer or producer. It is possible to make the consumer failure notification by telephone, fax, e-mail, registered mail or similar. However, in case of disagreement, the obligation of proof belongs to the consumer.
- 4) Product replacement or refund is mandatory depending on the choice of the consumer in case one of the conditions below:
 - a) If failure occurs in the product at least four times in one year or six times with the condition of being within the warranty period.
 - b) If the maximum time for its repair is exceeded.

c) In case a service station is not exist by a report issued by seller, dealer, agency, representative, importer or producer respectively that, repair of the failure is not possible, exchange process will be carried out free of charge.

d)The warranty period of the products changed during the warranty condition is limited to the remaining warranty period of the purchased products.

5)Free repair and product exchange obligations will be annulled under the following conditions:

a) If the product becomes faulty due to use contrary to the terms or conditions stated in the user guide,

b) If the product serial number has been altered or removed

c)The warranty labels have been destroyed,

d) If the product has been opened, used, or previously repaired by unauthorized persons,

e) Use of the product by plugging into inappropriate voltages or with faulty electric installation without the prior knowledge of our authorized services,

f) If the fault or damage to the product occurred during the transportation outside of the responsibility of SMS Sanayi Malzemeleri Üretim ve Satışı A.Ş.,

g) When our product is damaged due to use with accessories or devices purchased from other firms or unauthorized services,

h) Those damages caused by natural disasters such as fire, lightning, flood, earthquake, etc.

6) A report prepared by the SMS Sanayi Malzemeleri Üretim ve Satışı A.Ş. will determine whether the damage was caused by improper use.

7) The warranty certificate should be kept throughout the warranty period. The customer must provide the warranty certificate during request for repair. Otherwise, the cost of repair will be charged.

8) The warranty certificate attached to the product during sale should be fully completed by the retailer and customer, signed and stamped. The customer copy must be immediately provided to the customer, followed by the other piece to be mailed out to SMS Sanayi Malzemeleri Üretim ve Satışı A.Ş. by the retailer.

9) In the case when you send the product via courier, please remember to add a description your complaint, the photocopy of your warranty certificate, your address and telephone number.

10) For possible problems which may arise concerning the warranty certificate, it can be applied to the Ministry of Customs and Trade, Directorate General of Consumer Protection and Market Surveillance.



tork

valve & automation

HEAD OFFICE

Bostancı Yolu Cad, Kuru Sok, No16 Y, Dudullu, 34776 Ümraniye İstanbul - TURKEY

T +90 216 364 34 05 F +90 216 364 37 57

FACTORY

İMES O.S.B. 5. Cad, No 6 Çerkeşli O.S.B. Mah, Dilovası Kocaeli - TURKEY

T +90 262 290 20 20 F +90 262 290 20 21

SMS-TORK Endüstriyel Otomasyon Ürünleri San. Tic. Ltd. Şti.

f/SMSTORK @/sms-tork www.smstork.com